

ITEM	QTY	PART NO.	DESCRIPTION

120V-AC  
FROM 15A Service Plug

ON/OFF/AUTO selector allows operation without computer.  
OFF Selector forces CRR and spindle OFF.  
Auto Selector enables computer control of CRR and spindle.

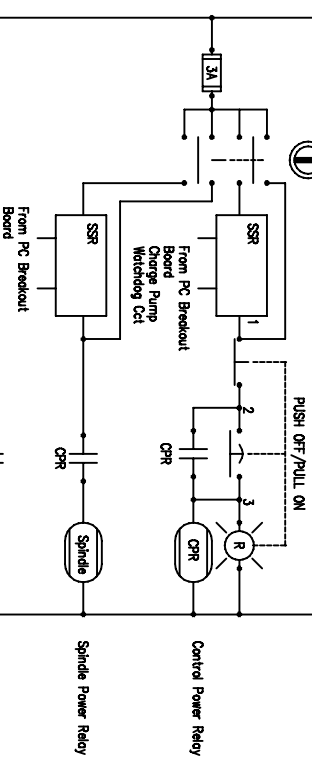

Spindle can be rewired for 220 if required.

Duplicate Outlet on Control Box For Spindle Motor or Drive

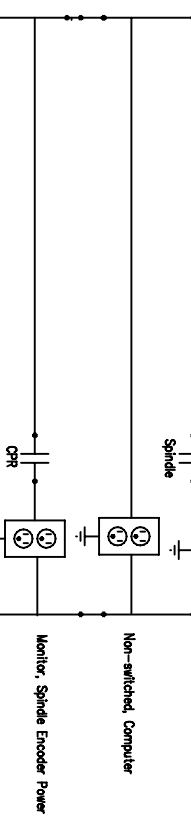

Pulling button activates remote input on OEL/750's Jumper Remote pin to current pin to make current drop to zero. See page 20/21 of OEL/750 manual.

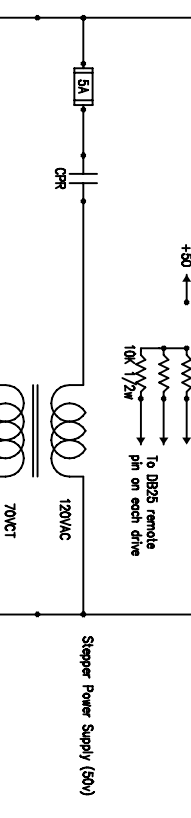

24VAC for dr spindle is generated from 35VAC winding. This can be rewired to primary side if you need 120VAC.

ON/OFF/AUTO selector:  
A5 800I-J5 with 2 800I-YA contact blocks

CRR/ESTOP Switch:  
A5 800I-F3A/F16 A7 with 4017I-002-01 120 volt transformer, 800I-JA7 contact block, and red mushroom head.

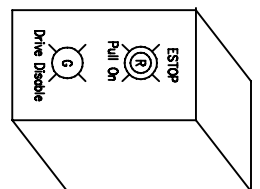

Operators controls located near machine.

SOFTWARE

TAISTER CONSULTING

HARDWARE

ANY-WARE

REV#	RCO No.	DATE	BY	DESCRIPTION

Control Cabinet Wiring  
3 Axis Stepper System

REV -  
SHT 1/1

A2 CNC0000  
DWG NO.